

P.C.B. LAYOUT

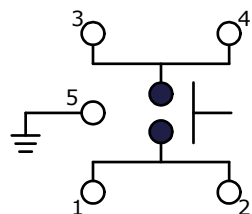

CIRCUIT: SPST

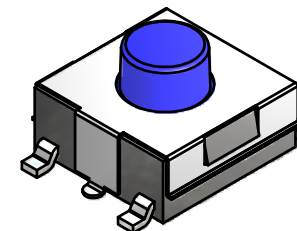
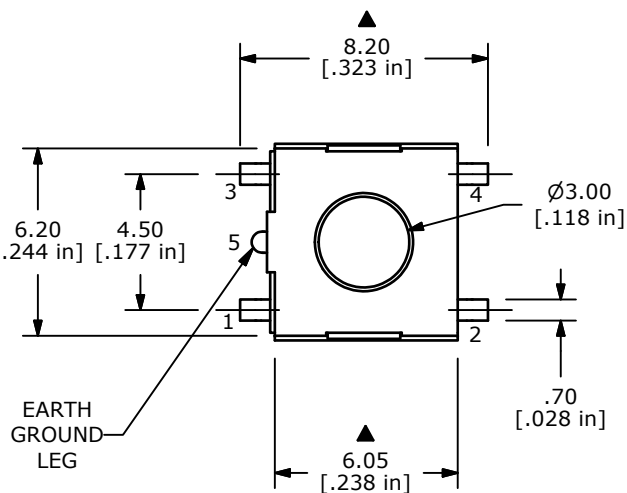

NOTES:

1. ALL DIMENSIONS IN MM [INCH]
2. GENERAL TOLERANCE: X.X \pm 0.4
X.XX \pm 0.25
3. TERMINAL NUMBERS FOR REF ONLY.
4. TRAVEL: 0.25mm +0.2/-0.1
5. RATING: 50mA, 12VDC
6. OPERATING FORCE: 260 \pm 50gf
7. CONTACT RESISTANCE: 100Milli-OHM MAX.
8. INSULATION RESISTANCE: 100 Mega-OHMS MIN.
9. DIELECTRIC STRENGTH: 250 VAC MIN.
10. LIFE EXPECTANCY: 100,000 TYPICAL
11. ACTUATOR COLOR: BLUE (SIMILAR TO PANTONE 3015C)
- ▲12. ACTUATOR MATERIAL: PA6T
13. ▲ DENOTES CRITICAL PARAMETER
- ▲14. PACKAGING: TAPE AND REEL 1,200 PCS PER
15. 2002/95/EC (ROHS) COMPLIANT

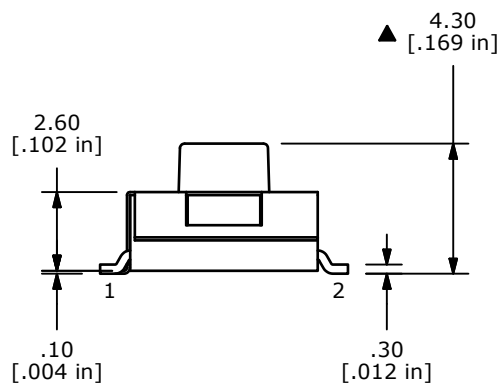

TERMINALS TO BE COPLANAR WITH IN 0.10 TOTAL

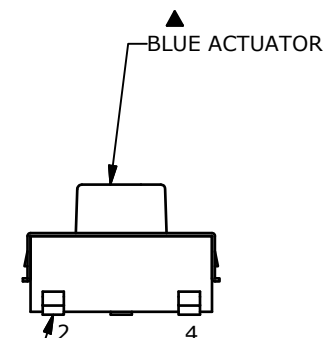

TITLE TLE3303AF260QGBLUACT

A	19897	Release For Production	4/28/11	BGL
REV	PCR NO	DESCRIPTION	DATE	BY

SCALE	DATE	DR	DWG	REV
4:1	4/28/2011	BGL	P010659	A

THE INFORMATION CONTAINED IN THIS DOCUMENT IS PROPRIETARY TO E-SWITCH AND IS NOT TO BE COPIED OR TRANSFERRED